

## SGV Series Slide Gate Valves

SGV series can be used as maintenance gate as well as opening and shut-off valves for free flowing of bulk solid material in silos, hoppers, weighing hoppers, inlet and outlet of screw conveyors and other similar applications. SGV Series slide valves comes with different execution materials, dimension options, sections and actuator alternatives to suit your needs

### Main Body

Main body can be produced in following materials:

- ST37
- ST52
- AISI304
- AISI316

### Blade

In addition to the main body material alternatives, blade can be manufactured from HARDOX aswell.

### Chute

Depending pn the application, chute can be supplied in following materials:

- EPDM
- Viton
- Food Grade

### Advantages of SGV Slide Valves

- Sliding system on roller bearings
- Special design with centered blade, sealed rubber gutter
- Low Profile connection height
- Operating temperature -40 +80 degrees

**Product Code System**

1	2	3	4	5	6	7
SGV	S	300	1	1	1	2

<b>1</b>	Product Type	Slide Gate Valve					
<b>2</b>	Section	C	Circular	S	Square		
<b>3</b>	Inlet Dimension	150	150mm	200	200mm	250	250mm
		300	300mm	350	350mm	400	400mm
<b>4</b>	Body	1	ST37	2	ST52		
		3	AISI304				
		4	AISI316				
<b>5</b>	Blade	1	ST37	2	ST52		
		3	AISI304				
		4	AISI316		5	HARDOX	
<b>6</b>	Chute	1	EPDM	2	Viton		
		3	Food Grade				
<b>7</b>	Actuator	0	W/O		1	Manual	
		2	Pneumatic				
		3	Electirc				

## Label

Serial Number (Product Type/Production Year/Production Month/Unit Number  
in Production Line

Product General Specs (Section/Size/Body Material  
/Blade Material/Chute Material Actuator)

Product Code (See "Product Code System")

Product: <u>SVGS3001112</u>	Serial No: <u>SGV2408-01</u>
Square 300mm ST37 ST37 EPDM Pneumatic	2024
	
<b>FUBAA</b> CONCRETE MACHINERY, ENGINEERING	
<b>EAC</b>	
<a href="http://www.fubaamachinery.com">www.fubaamachinery.com</a>	
<b>MADE IN TÜRKİYE</b>	
Manufacturer: Proer Makine ve Sanayi ve Ticaret Limited Şirketi Saray Mahallesi, 675. cadde 8/B Kahramankazan / Ankara	

**SGVC Dimensions**

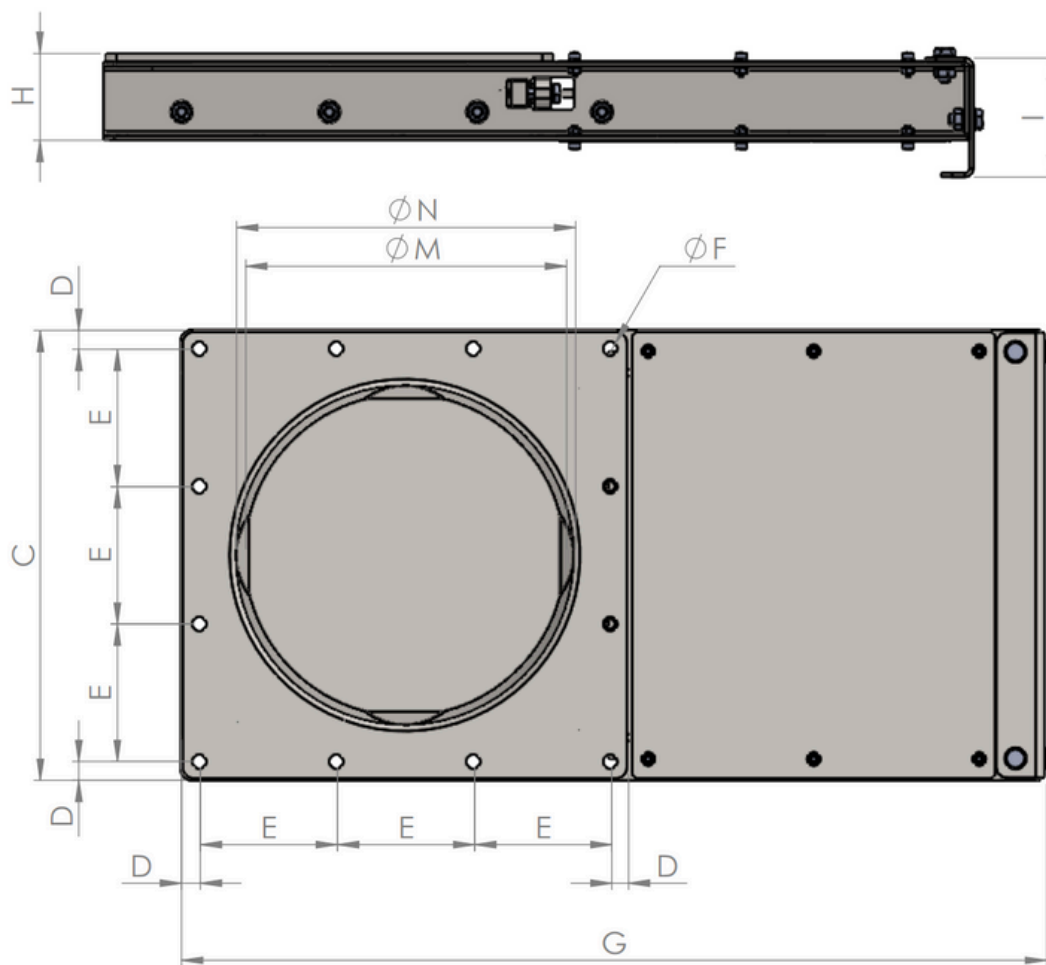

SGVC	Ø M	Ø N	C	D	E	E <sub>Nr</sub>	Ø F	Bolts	G	H	I
<b>150</b>	150	165	270	20	115	2	12	M10	595	80	110
<b>200</b>	200	215	320	20	93,3	3	12	M10	710	80	110
<b>250</b>	250	265	370	20	110	3	12	M10	695	80	110
<b>300</b>	300	320	420	17,5	128,3	3	12	M10	810	80	110
<b>350</b>	340	360	480	17,5	89	5	12	M10	950	90	125
<b>400</b>	390	415	530	15	100	5	12	M10	1010	90	125

**SGVS Dimensions**

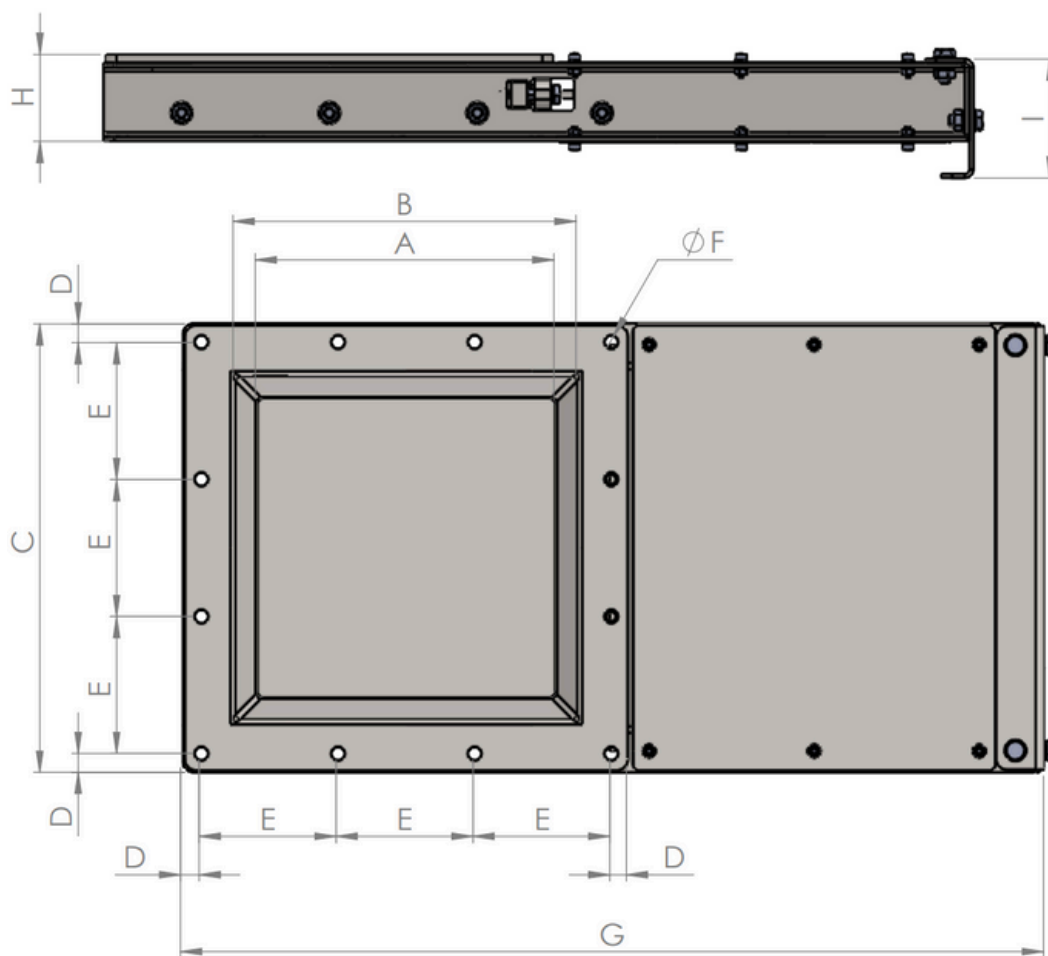

SGVS	A	B	C	D	E	E Nr	Ø F	Bolts	G	H	I
<b>150</b>	130	175	270	20	115	2	12	M10	595	80	110
<b>200</b>	180	225	320	20	93,3	3	12	M10	710	80	110
<b>250</b>	230	275	370	20	110	3	12	M10	695	80	110
<b>300</b>	280	325	420	17,5	128,3	3	12	M10	810	80	110
<b>350</b>	330	375	480	17,5	89	5	12	M10	950	90	125
<b>400</b>	380	420	530	15	100	5	12	M10	1010	90	125

### SGV Components

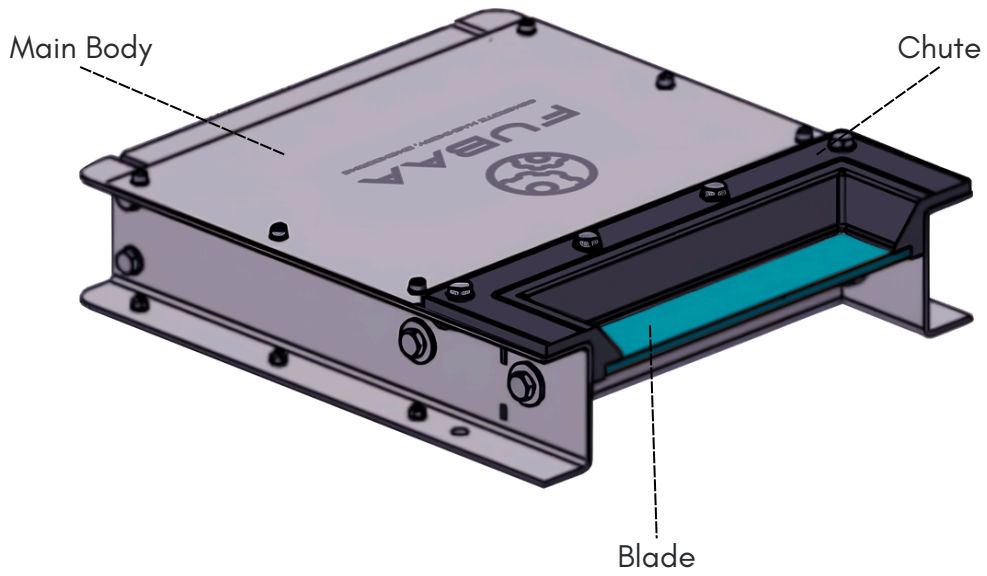

Body	ST37	ST52	AISI304	AISI316
------	------	------	---------	---------

Blade	ST37	ST52	AISI304	AISI316	HARDOX
-------	------	------	---------	---------	--------

Chute	EPDM	Viton	Food Grade
-------	------	-------	------------



# FUBAA

CONCRETE MACHINERY, ENGINEERING

Established by one engineer and one sales person, FUBAA brand aims to expand it's existence to where the others fear.

Being extremely flexible and quick, gives our brand a huge advantage over the others. Having over 10+ years of experience in bulk handling materials, FUBAA brand can, not only produce the "product" customer needs, but can also to supply, re-design and export what already exists.