





FUBAA

CONCRETE MACHINERY, ENGINEERING



SCREWS AND SCREW CONVEYORS

Available execution materials: Carbon steel, stainless steel, galvanised steel.

Body type: Tubular, U shaped, V shaped, special design.

Diameter: From 90mm all the way up to 400mm.

Inlet/Outlet options: Tubular, square, rectangular, conical, with and without flange.



Drive group: Outsourced local (TR) or European brands. Soon to be equipped with in-house made gearbox.

Applications: Standard units for cement and similar. Semi heavy duty units for asphalt plant applications and similar. Heavy duty units for quartz and similar.



FUBAA

CONCRETE MACHINERY, ENGINEERING



FILTERS

FILTERS

Filtration area - 6m² to 36m²

Filtering elements - Cartridges or bag type filters

Cleaning - Pneumatic

Body - stainless steel or carbon steel, diameter 400mm, 600mm, 800mm and 1200mm.

Cover - stainless steel or carbon steel

Connecting flange - always included

Various fan options from 0.75kW to 11kW

Applications: Standard units for cement and similar. Semi heavy duty units for asphalt plant applications and similar. Heavy duty units for quartz and similar.



Applications: Standard units for cement and similar. Semi heavy duty units for asphalt plant applications and similar. Heavy duty units for quartz and similar.



FUBAA

CONCRETE MACHINERY, ENGINEERING



SLIDE GATES

SLIDE GATES

Main body -ST37 galvanized or stainless steel

Sliding system on roller bearings

Special design with centred blade, sealed rubber gutter

Square or round section with dimensions from 150mm to 400mm

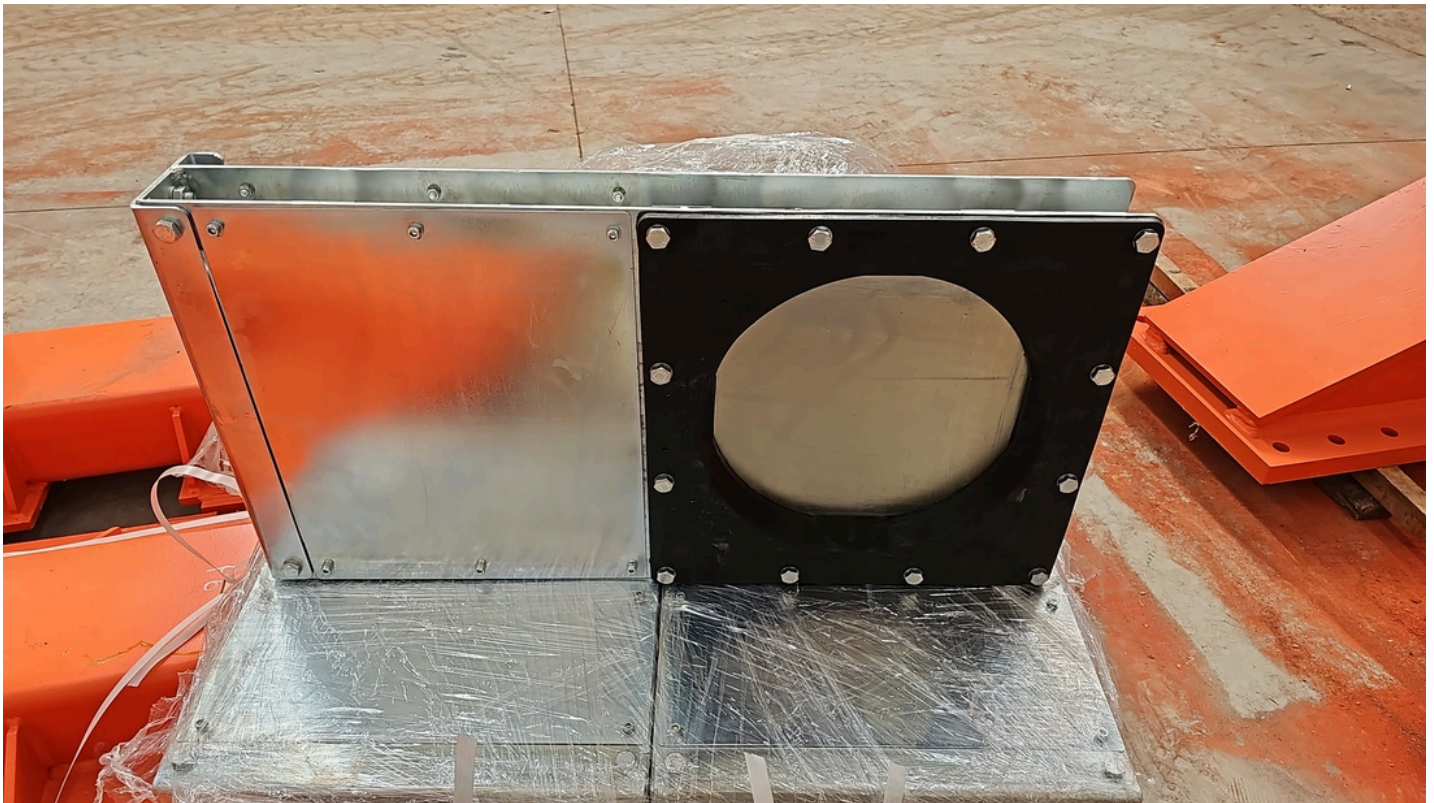

Low Profile connection height

Manual, pneumatic or electric actuator options

Operating temperature $-40 +80$ degrees



FUBAA

CONCRETE MACHINERY, ENGINEERING



LOADING BELLOWS

LOADING BELLOWS

Metal parts, which are contact with material: Stainless steel, carbon steel

Bellow: Single or double walled

Nominal capacity: 250m³

Internal metal cones: Carbon steel, stainless steel or hardox on request

Extended height (from inlet flange to edge of outlet): Almost any length

Retracted length (from inlet flange to edge of outlet): Almost any length

Electric motor: 0.75Kw or more

Level indicator: 230VAC/24DC paddle type

Filtering system: 10m² filtering area on request

Included: Control system (panel and remote), bottom closure cone





FUBAA

CONCRETE MACHINERY, ENGINEERING



CONCRETE MIXER SPARE PARTS

CONCRETE MIXER SPARE PARTS



Suitable spare parts for brands like CM, SIMEM, SICOMA, MEKA and many more.

Spare parts for mixing group, sealing group, wear parts and drive group can be provided.

Mixing arms and blades, scrapers, main shaft, wall linings, body wear plates, gearboxes, complete sealing groups or sealing repair kits, lubrication systems.

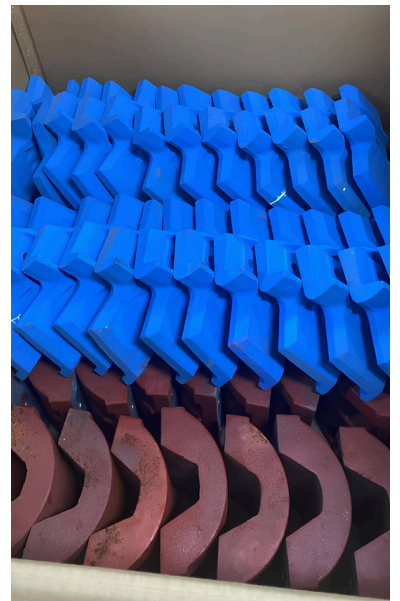



FUBAA

CONCRETE MACHINERY, ENGINEERING



SILO EQUIPMENT

Ranging from small bunkers, all the way up to 2000-3000 tons.

Standart silo equipment;

Silo filter

Pressure relief valve

Level indicator

Air jets

Butterfly valve / slide gate valve

Silo Filters

Depending on the size of the silo, it can be a small 12m² filter with cartridge or 2-3 pieces of 36m² bag type filtering elements. Some applications might even require fan.

Pressure Relief Valve

Depending on the silo capacity, quantity of these elements will change.

Level Indicators

Most silos will be fine with 2 but for some applications /systems 3 indicators will be the suitable option.

Air Jets

Depends on the diameter of the silo. While a standard 100 ton silo would require like 10 pieces, you might need x5 of them for a 500 tons silo.

Valve

Depending on the capacity of the silo and bulk material inside, you can choose between a butterfly valve or slide gate valve. If silo is very big and material's density is high, slide gate valves will be more effective at stopping the material flow. For lighter applications like concrete plant cement silos, butterfly valves are the product to go.





FUBAA

CONCRETE MACHINERY, ENGINEERING

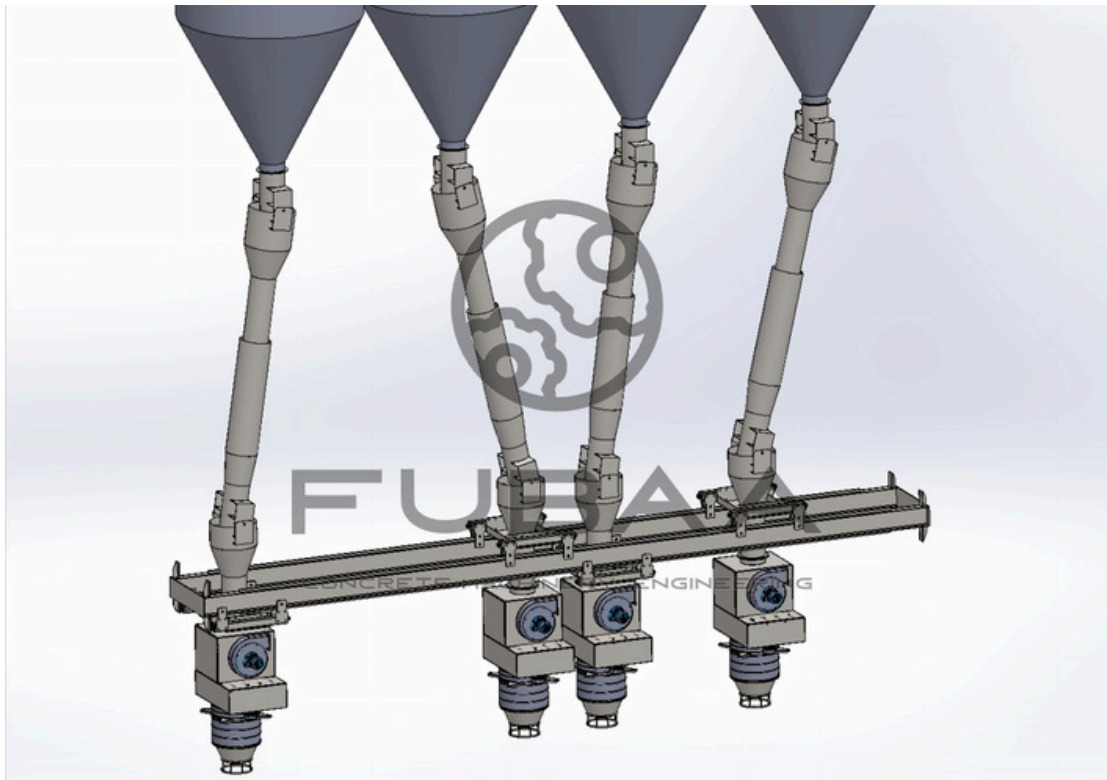

SPECIAL PROJECTS

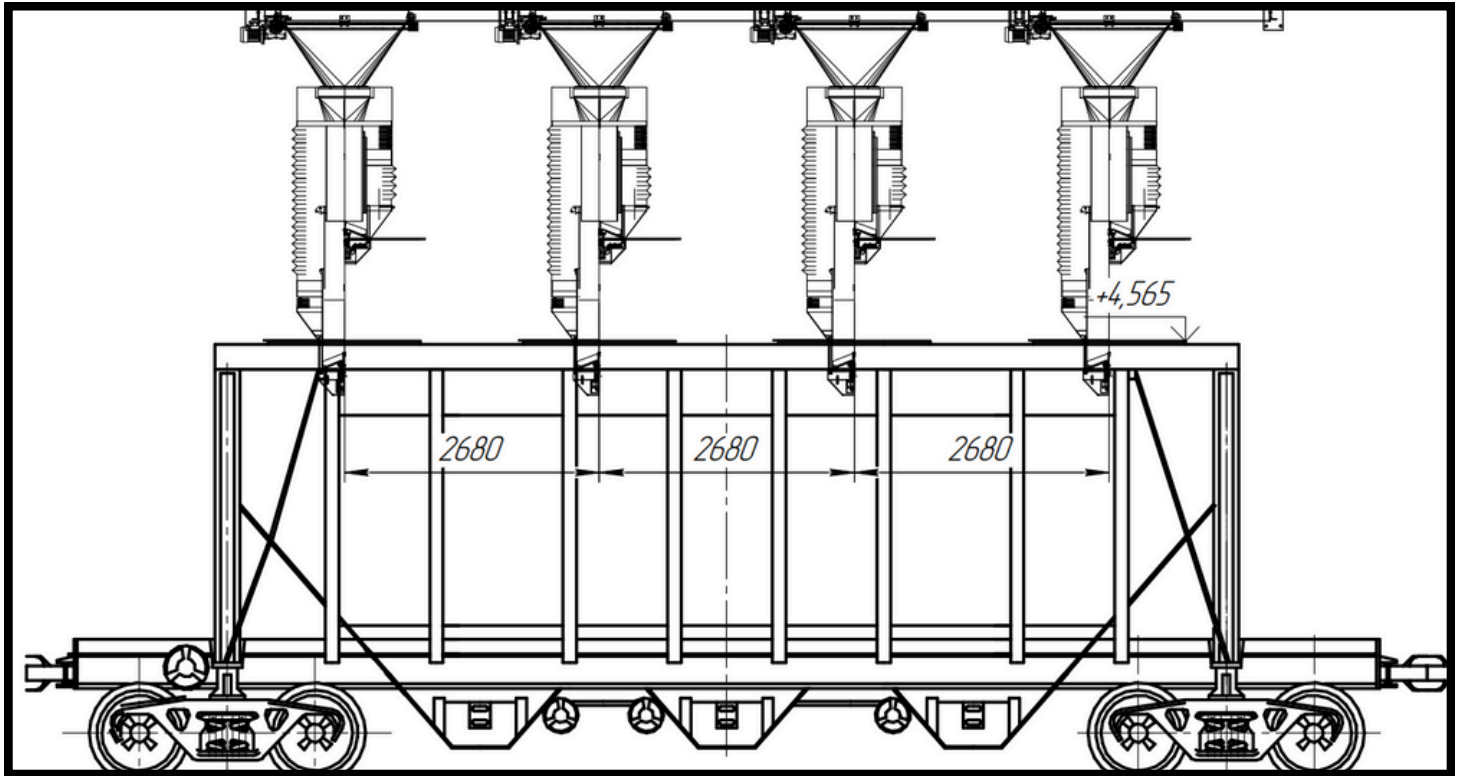

All types of metal work, project design, production per customer drawings, modified versions of standard issue bulk handling products and many more





FUBAA

CONCRETE MACHINERY, ENGINEERING

Established by one engineer and one sales person, FUBAA brand aims to expand it's existence to where the others fear.

Being extremely flexible and quick, gives our brand a huge advantage over the others. Having over 10+ years of experience in bulk handling materials, FUBAA brand can, not only produce the "product" customer needs, but can also to supply, re-design and export what already exists.